

[GAS DETECTOR]

REFERANC MANUSL

MODEL: EW-503 (LNG.LPG)



[NOTICE]

- Surely be aware of the specifications by skilled worker prior to using the product
- Surely keep the specifications to where you are always able to see

[LIST]

1. Specifications
 - 1-1. Indicator
 - 1-2. Sensor
2. Part & Function
 - 2-1. Indicator
 - 2-2. Main panel
 - 2-3. Unit panel
 - 2-4. Sensor
 - 2-5. Composition of Indicator
 - 2-6. Composition of Sensor
3. Wiring Diagram
 - 3-1. Power supply
 - 3-2. Terminals of Unit panel
4. Operational system
5. Installation
 - 5-1. Where to install
 - 5-2. Installation drawing
6. Instructions & Cautions
7. Dimensions
 - 7-1. Indicator_ Front view, side view
 - 7-2. Sensor_ Front view side view

*User's manual is not responsible for unauthorized changes.

1. Specifications

1-1. Indicator

Model	Gas Detector EW-503
Detectable Gases	LPG, LNG, City gas, Combustible gas, Toxic gas
Power supply	AC 220V. 60Hz
Power consumption	3.5W per Unit panel
Operating Temperature	0°C~ 40°C
Operating Humidity	Below 95% (RH)
Detection Range	0~100% LEL
Alarm point	Combustible gas-below 25% LEL (The alarm point is 18%LEL now) Toxic gas-Dependent on target gas
Visual Alarm	YELLOW LED blinking on Main panel, RED LED blinking on UNIT panel
Audible Alarm	Buzzer sound
Output	25mA (about 9V DC) COM.NC.NO (Dry contact)
Operating / Fault	GREEN LED / RED LED short sound
Warm up time	About 1 min
Cabling	VCT, VCTF,CVVS (greater than 0.75mm)
Battery	Ni-Cd storage battery DC 12V 600m Ah
Relay contact	110/ 220V (1A)

1-2. Sensor

Model	EWEX IIB 100
Type	Diffusion
Detectable Gases	LPG,LNG, City gas, Combustible gas, Toxic gas
Detection Technique	Catalytic combustion
Operating Temperature	-20°C~40°C
Operating Humidity	Below 95% (RH)
Explosion-Proof	Ex d II B T6
Power supply. Power consumption	DC 12V/ 24V, 2.4W
Dimensions	140*142*75 mm
Weight	858g
Detection range	0~100% LEL
Response time	Within 20 sec
Housing material	Aluminum
Place to use	Indoor place

2. Part & function

2-1. indicator



① main panel_

- 1.Receiving the alarm signal form unit panel, it makes Visual and Audible alarms
- 2.Receiving the fault signal from unit panel, it makes fault alarms (short sound)
- 3.It supplies the unit panel with DC power

② unit panel_

- 1.Connected with sensor, it shows the concentration of gas and visual alarm
- 2.When there are faults in the sensor, it show fault alarm
- 3.It can perform the test of the circuit

③ Instruction_ It shows specifications, serial number, cautions and manual

2-2. main panel

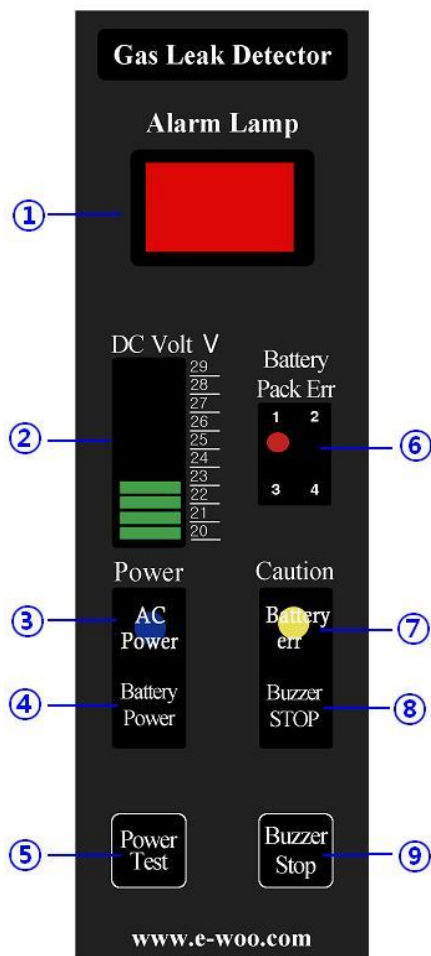

1. Warning light(alarm)

-YELLOW light blinks when gas is Detected. Eliminated in normal Condition.

2. Voltmeter

-It displays the electrum motive force in Volts of the main power or battery

3. Main power light

-GREEN LED is it while supplied by AC220V

4. Battery light

-GREEN LED is it while supplied by battery (in case of power-failure)

5. Battery test button(power test)

-It allows the user to check the power supply of battery pressed, it switches form Main power supply mode to battery mode

6. Battery monitoring light-

7. Battery warning light – YELLOW LED gets lit when battery has troubles or It is disconnected or its fuse has blown. Or it is switched off

8. Alarm mute warning light(BZ stop)- YELLOW LED blinks if the alarm mute Button is pressed. And during this time, the audible alarm is mute In spite of the alarm condition. And if the button is pressed again. The light is eliminated and the buzzer becomes audible again

9. Alarm mute button (Buzzer stop)-It allows the user to silence the buzzer when it's alarm condition. If pressed one time. Buzzer becomes mute. And pressed again. Buzzer becomes audible again

2-3. unit panel

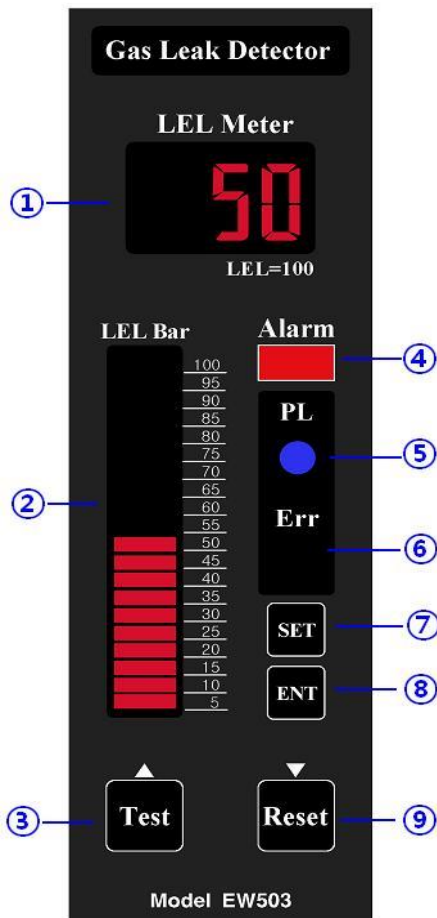

- ① Digital display (LEL meter)
-It shows the concentration of gas on 7 segment display
- ② LED bar display (LEL bar)
-It show the concentration of gas on LED bar display
- ③ Test button
-It allows the user to check the circuit of the Unit panel. If it is pressed. The concentration of gas increases. As if gas is detected actually. And if the concentration Exceeds the alarm point the audible alarm beeps
- ④ Warning light (alarm)
-RED LED blinks when gas is detected. Eliminated in normal condition

- ⑤ Power supply light (PL) – GREEN LED is lit while supplied by AC220V. but while the unit panel is warmed up, the light blinks
- ⑥ Fault light (err) – GREEN LED is lit when the sensor connected with the Unit panel has troubles. e.g Disconnection, short circuit
- ⑦ SET button-Any consumer cannot adjust
- ⑧ ENT button- auto zero
- ⑧ Reset button- It allows the user to reset the concentration on the unit Panel. But if the concentration of gas exceeds alarm point. The alarm condition is not reset

2-4. sensor

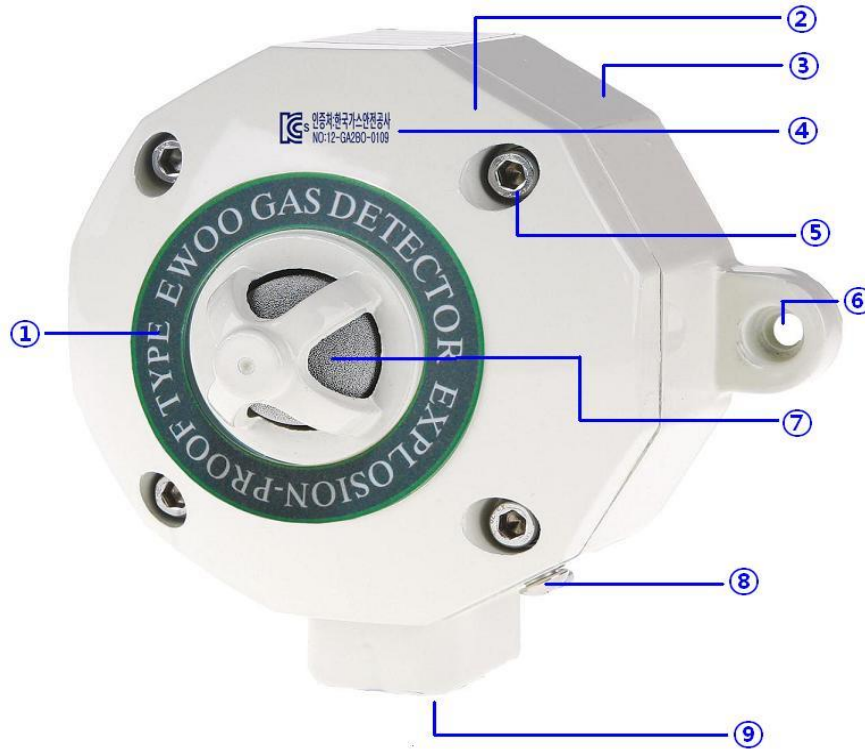

- ① Sticker (Explosion proof)
- ② Sensor cover ③ Sensor body
- ④ Explosion proof approval sticker (Korea gas safety corporation approval)
- ⑤ Cover fixing bolt: The bolt for fixing cover and body of detector
(Wrench bolt M5*15)
- ⑥ Sensor fixing hole: The hole for fixing the detector by bolts or nails
- ⑦ Sensor protection filter: sensor protection filter(bronze 300mesh)
- ⑧ Ground earth: M4*6mm
- ⑨ Cable grand: Do sealing fitting properly or access using cable glands passed the Safety certification. When the way of inlet pipes and tubes of metal wires in areas that Require explosion-proof



2-5. Composition of indicator

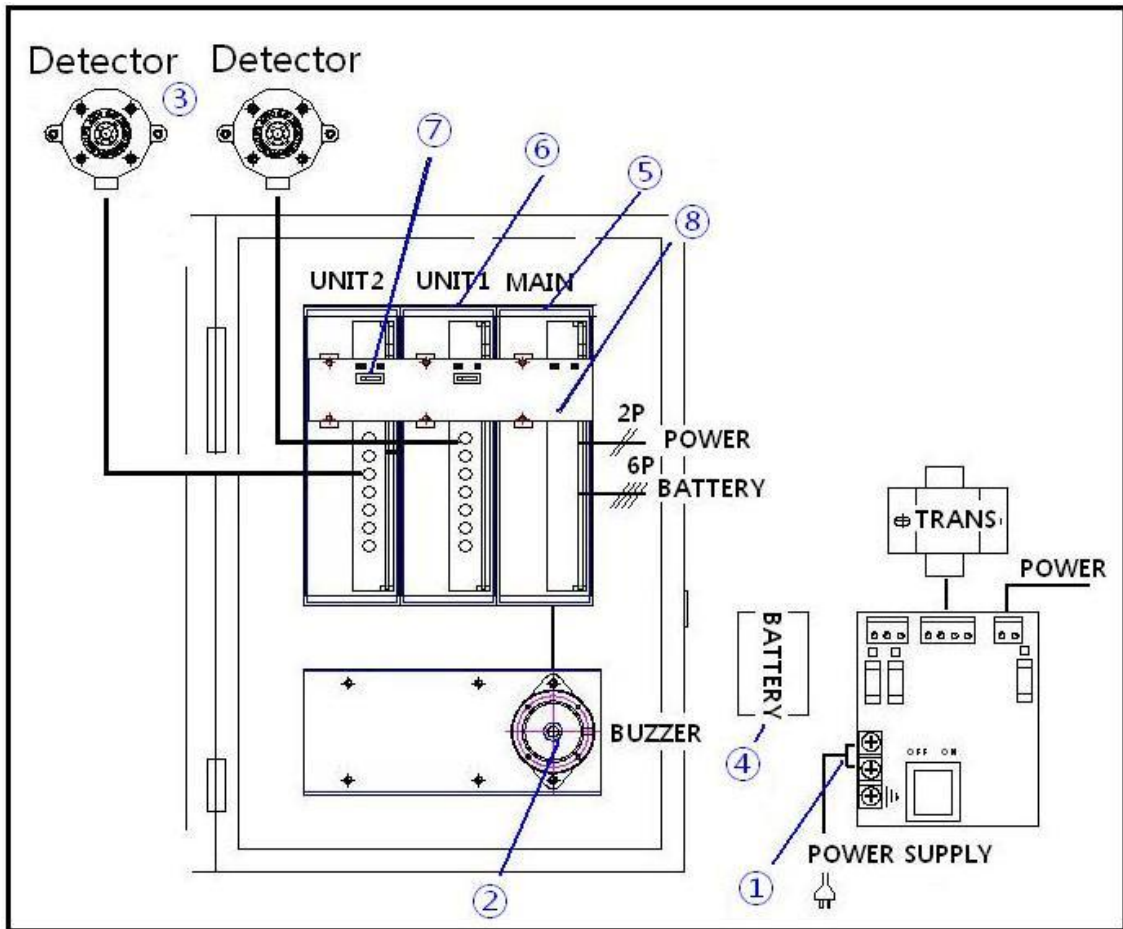

- ① Power terminal: Please connect with rated voltage (AC 220V)
- ② Buzzer: When it's alarm condition. It makes audible alarm. And when there are Faults. It makes audible fault alarm(short sound) as well
- ③ Sensor: It detects the gas
- ④ Battery Extension: If you are to use 3 or 4 battery
- ⑤ Main panel: please refer to chapter 2-1
- ⑥ Unit panel: please refer to chapter 2-2
- ⑦ Unit power s/w
- ⑧ Unit panel switch

2-6. Composition of sensor

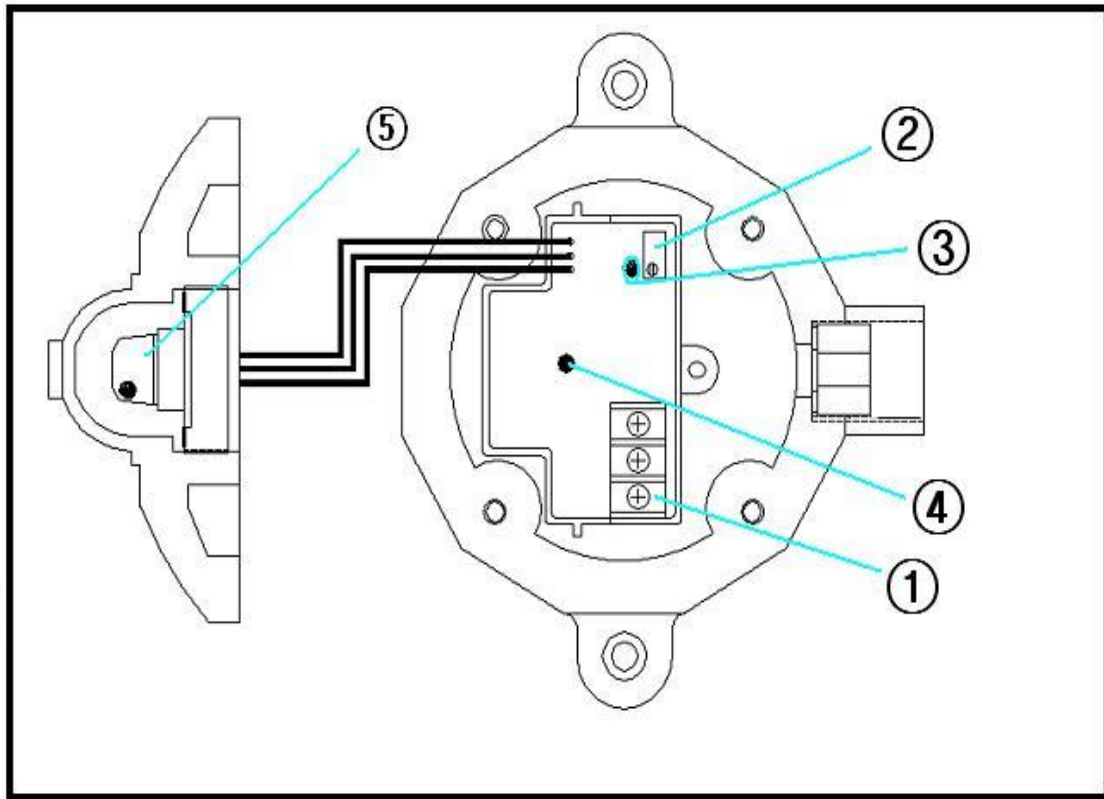

① Connector (Terminal block)

Blue (White) +	Brown (Black)-	Green (Wire of signal)
Power supply of sensor + (DC 24V)	Power supply of sensor - (DC 24V GND)	Output of Sensor (4~20mA)

- ② Zero Calibration - We release the detector with it being set. Do not attempt to modify.
- ③ Concentration light - The brightness of Yellow light changes in proportion to the Concentration of Gas (eliminated in normal condition)
- ④ Power supply light - Green LED is lit while supplied with Power.

3. Wiring Diagram

3-1. Power supply

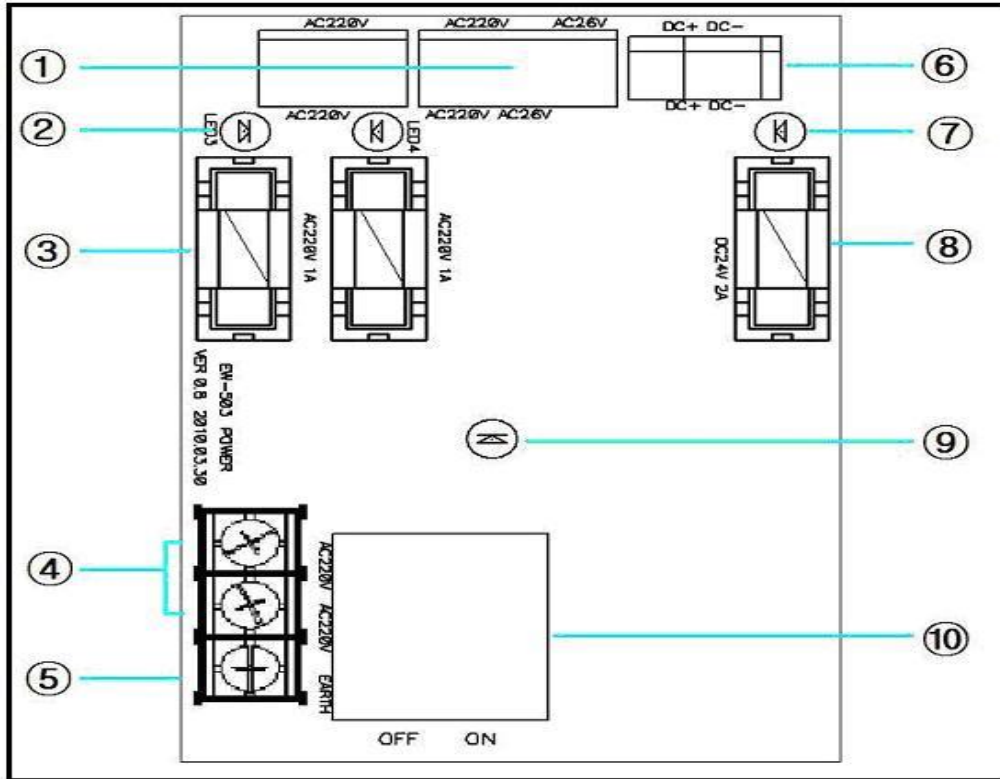

① Trans connector

unit	Trans capacity	DC FUSE capacity	Battery quantity
1~4 Channel	1A	1A	1EA
5~7 Channel	2A	2A	2EA
8~10Channel	3A	3A	8C(2EA) 9~10C(3EA)

- ② AC fuse lamp
- ③ Fuse for the main power supply – 1A. 250V
- ④ Power terminal AC220V
- ⑤ Earth terminal
- ⑥ DC power connectors.
- ⑦ Warning light of the Fuse for the DC power supply- It gets lit when the Fuse for the DC power supply has blown
- ⑧ Fuse for the DC power supply – 2A.
- ⑨ DC power led lamp
- ⑩ Power supply switch (AC 220V)

3-2. Terminals of unit panel

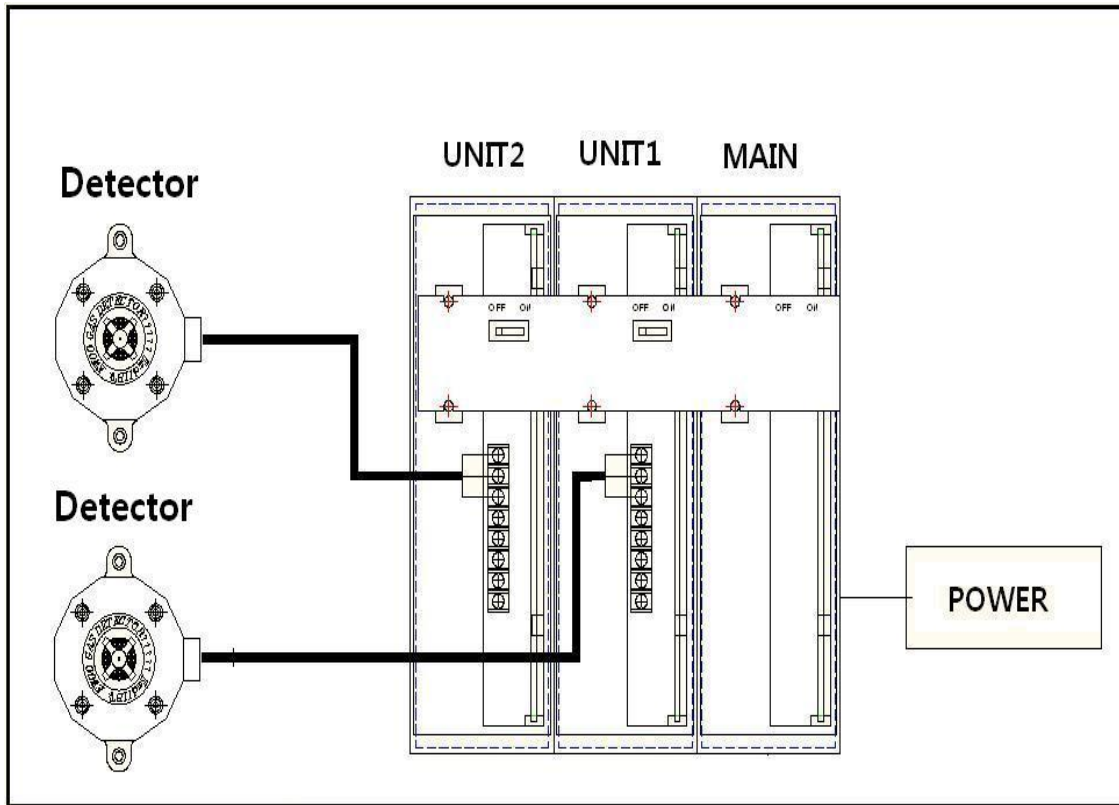

- ① Fuse for the Sensor – (It is covered) 0.8A (sensor, DC 9V alarm output)
- ② Warning light of the Fuse for the Sensor – It gets lit when the Fuse for the Sensor has blown
- ③ Output light – It gets lit When the UNIT panel outputs the alarm signal to the Control panel and others. (DC 9V 15mA)
- ④ UNIT panel switch – You can turn the UNIT panel on & off by flicking this switch
- ⑤ Sensor connector – Please match the wires with terminals in color.

Blue (White) +	Brown (Black)-	Green (Wire of signal)
Power supply of sensor + (DC 24V)	Power supply of sensor – (DC 24V GND)	Output of Sensor (4~20mA)

- ⑥ Dry contact (NO.NC.COM) - In normal condition, COM terminal is connected with NC terminal. And in alarm condition, COM terminal is connected with NO terminal
- ⑦ Output terminal - This terminal is used when the UNIT panel outputs the alarm signal to the Control panel and others. (DC 9V 15mA)

4.Operational system

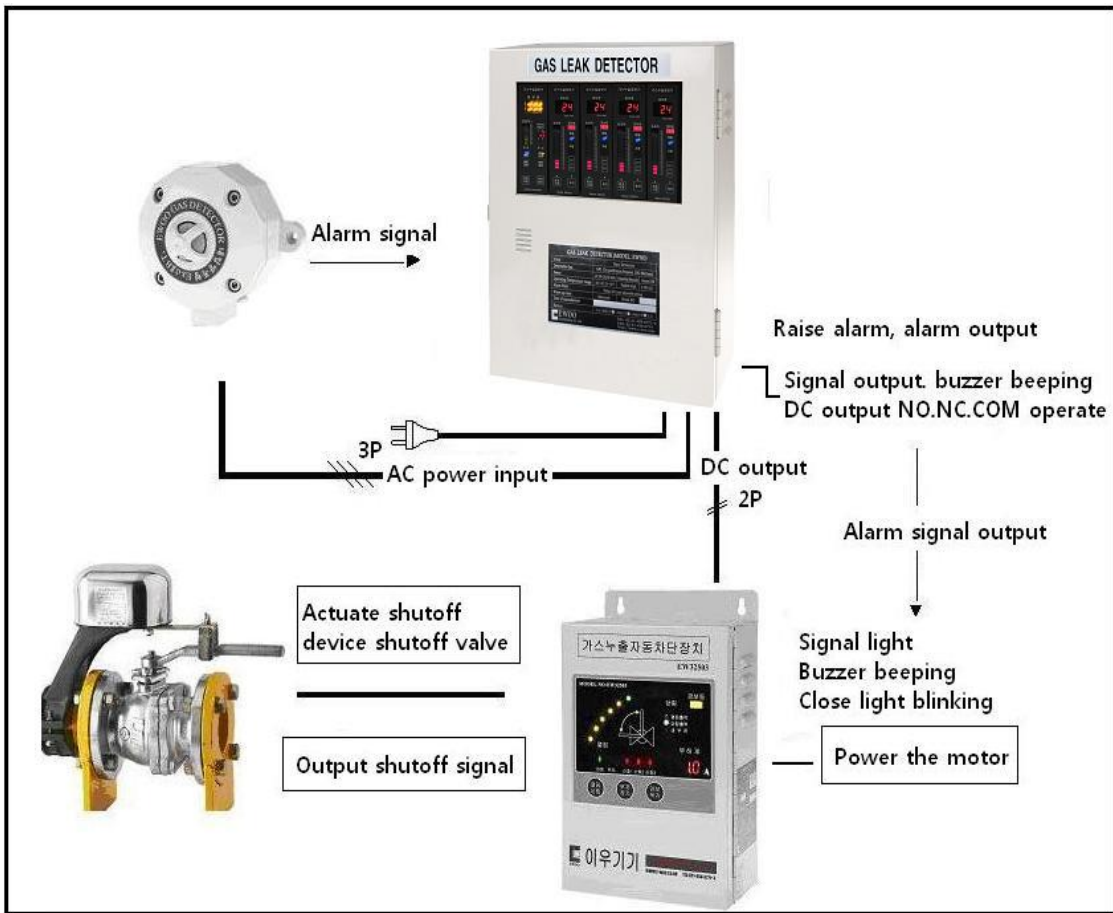

5. Installation

5-1. Where to install

- ① The detector is designed to be installed in the area that is subject to
Expose to gas or the area where the leaked gas tend to stay.
- ② Please determine the location of the Sensor considering the kind of the gas,
cautions and condition.
 1. If you are to detect the gas that is heavier than air, Sensor should be
Mounted at floor or the wall within 30cm from floor. And if you are to
detect the gas that is lighter than air, Sensor should be mounted at the
ceiling or the wall within 30cm from ceiling.(Plus: Sensor should be farther
than 1m and within 4m from the gas appliances)
 2. Please install the Detector at the place that the audible alarm is able to be
Heard so that manager can take follow-up measures.

5-2. Installation drawing

※PLACE TO INSTALL: Kitchen, Boiler room, Room of Pressure regulator, Gas storage

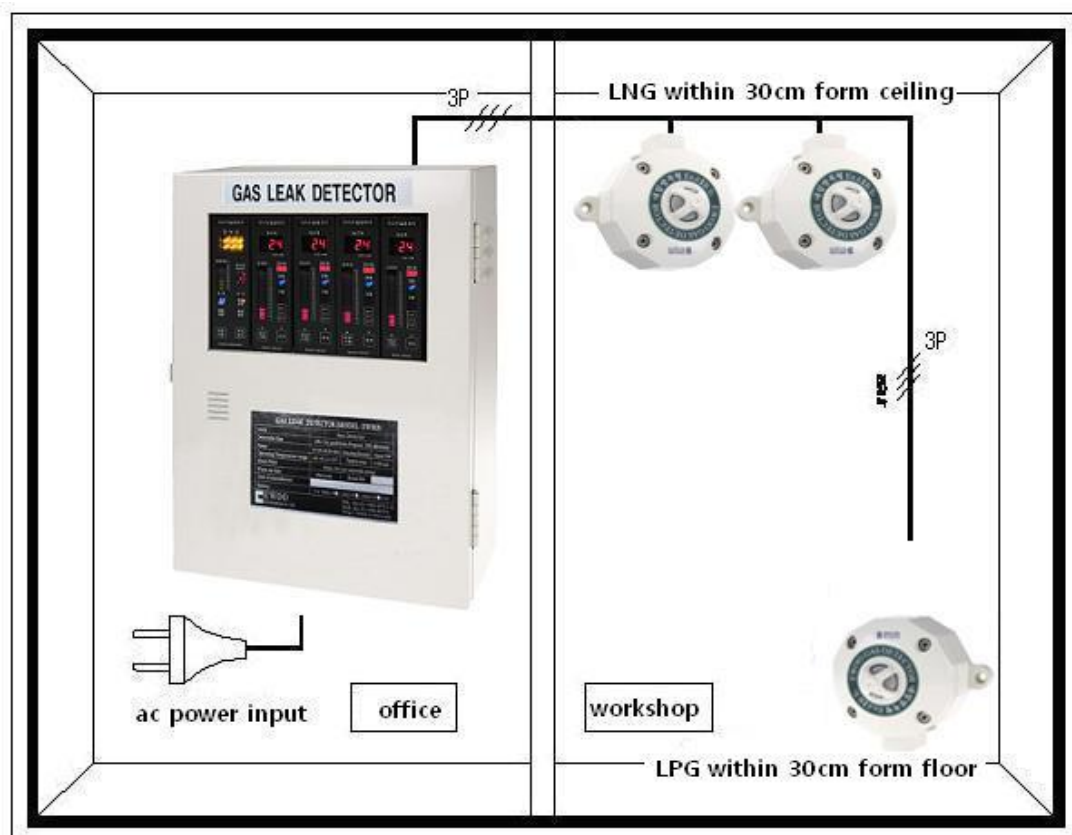

6. Instruction & cautions

6-1. Instruction

1. Please open the case and connect the Sensor with the Indicator. And connect the AC 220V power supply as well.
2. Please turn on the power supply switch and wait for warm up time (1 minute).
In 1 minute, the Detector begins to operate.
3. Fault light (err) on the UNIT panel gets lit when the fuse for the Sensor has blown or the Connection wire between the Sensor and the Indicator is disconnected or short-circuited. Or the sensitivity of the Sensor has been lost.
4. If you are to test the operation of the Detector, please press the Test button on UNIT panel. Then the concentration increases as if gas is detected actually. And if the level exceeds the alarm point, the Detector makes Visual and Audible alarms.
5. If you want to stop the audible alarm, please press the alarm mute button. If you do, Alarm mute warning light blinks and the audible alarm becomes mute.
6. When the fault light gets lit, please check the connection between Sensor and Indicator.

6-2. CAUTIONS

1. Do not attempt to disassemble, repair, remodel or convert.
2. If you purchase the product which has earth terminal, please install an earth wire.
3. Do not touch the power cord or main body with wet hand.
4. Do not disturb the ventilation of the Sensor
5. Be careful not to damage the power cord.
6. Be cautious about using the silicon glue which could affect the Sensor. Silicon glue could cause malfunctioning.
7. Please use the rated voltage (AC 220V) written on the product.
8. Do not spray the Sensor directly with air freshener, insecticide, hair spray etc.
9. Please use standard gas when testing.
10. Please connect Indicator with same Sensor in serial number.
11. Do not use for the gas that is not target one.
12. Please check the sensing device more than once a year.
13. Areas to avoid
 1. Near drafts caused by heating, ventilating, fans and doors
 2. Near vapor, steam, exhaust gas, dust, strong wind and other gases
 3. Areas of high heat and humidity.

7. Dimensions

7-1. Indicator- front view, side view

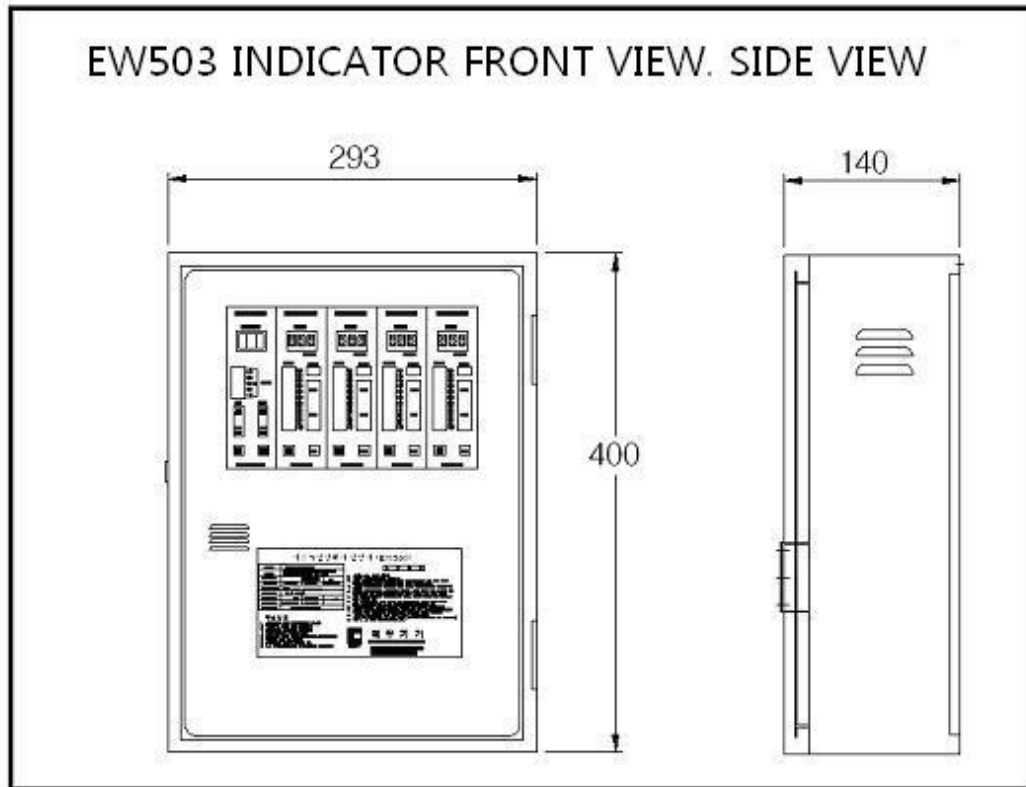

7-2. Sensor- front , side view

