

GAS DETECTOR

REFERANCE MANUAL

MODEL: EW-403 (LNG.LPG)



[NOTICE]

- Surely be aware of the specifications by skilled worker prior to using the product.
- Surely keep the specifications to where you are always able to see.

[CONTENTS]

1. SPECIFICATIONS
 - 1-1. INDICATOR
 - 1-2. SENSOR
2. PART & FUNCTION
 - 2-1. INDICATOR
 - 2-2. SENSOR
3. COMPOSITION
 - 3-1. INDICATOR
 - 3-2. SENSOR
4. OPERATIONAL SYSTEM
5. INSTALLATION
 - 5-1. Where to install
 - 5-2. Installation drawing
6. INSTRUCTION & CAUTIONS
7. DIMENSIONS

*User's manual is not responsible for unauthorized changes

1. SPECIFICATIONS

1-1. INDICATOR

Model	Gas Leak Detector EW-403
Detectable Gases	LPG, LNG, City Gas, Combustible Gas, Toxic Gas (NH3.H2)
Power supply	AC 220V. 60Hz
Power consumption	Normal condition - 2.5W. Alarm condition - 3W
Operating Temperature & Humidity	0°C ~ 40°C, Below 95%(RH)
Detection Range	0 ~ 100% LEL
Alarm point	Combustible gas- below 25% LEL (The set point is 18% LEL now)
Response time	Within 20 sec
Concentration display	3 FND 10 LED bar
Visual & audible Alarm	Yellow LED blinking, Buzzer Sound (above 70dB)
Operating	Green LED
Fault	Yellow LED, buzzer sound (short sound)
Warmup Time	about 1 min.
Cabling	VCT, CVVS (above 0.75mm)
Dimensions	144*258*86mm
Output	DC 12V (20~30mA). Dry contact (COM.NO.NC)
Relay contact	AC 220, 1A
Weight	about 1,718g

1-2. SENSOR

Model	EW EX II B 100
Detectable Gases	LPG, LNG, City Gas, Combustible Gas, Toxic Gas
Detection Technique	Catalytic combustion, diffusion
Operating Temperature & Humidity	-20°C~50°C. below 95% (RH)
Explosion-Proof	Exd II BT6
Conduit entry	16mm inside diameter, 23mm outside diameter
Dimensions	140*142*75 mm
Weight	1,016g
Detection range	0~100%(LEL)
Response time	within 20 sec

2. PART & FUNCTION

2-1. INDICATOR



①Power light : Green LED is lit while Supplied by AC 220V.

②Alarm mute warning light: Buzzer Stop Yellow LED blinks if the alarm Mute button is pressed. And during this time, the audible alarm Is mute in spite of the alarm condition. And if the button is pressed again, the light is eliminated and the buzzer becomes audible again.

③Test button: It allows the user to Check the circuit of the UNIT Panel. If it is pressed, the concentration of gas, as if gas is detected actually. And if the concentration exceeds the alarm point the audible alarm beeps

④Alarm mute button: If allows the user to silence the buzzer when it's alarm condition. If pressed one time, buzzer becomes mute. And pressed again, Buzzer becomes audible again

⑤Reset button: It allows the user to reset the value of the concentration. But if the Concentration of gas exceeds alarm point the alarm condition is not reset.

⑥LED dot display: It displays the concentration of gas on LED dot display

⑦Warning light(ALARM): Yellow LED blinks when gas is detected, eliminated in normal condition

⑧Digital display: It displays the concentration of gas on 7segment display

: If the concentration exceeds the point and the value of the concentration is maintained For several seconds, it displays letter GAS and the value of concentration by rotation (If the concentration keeps changing the changing value of concentration is displayed only)

⑨Fault light (ERROR): It gets lit when the fuse for the sensor has blown. Or the connection Wire between the sensor and the indicator is connected or short-circuited. Or the sensitivity of the sensor has been lost

2-1. SENSOR

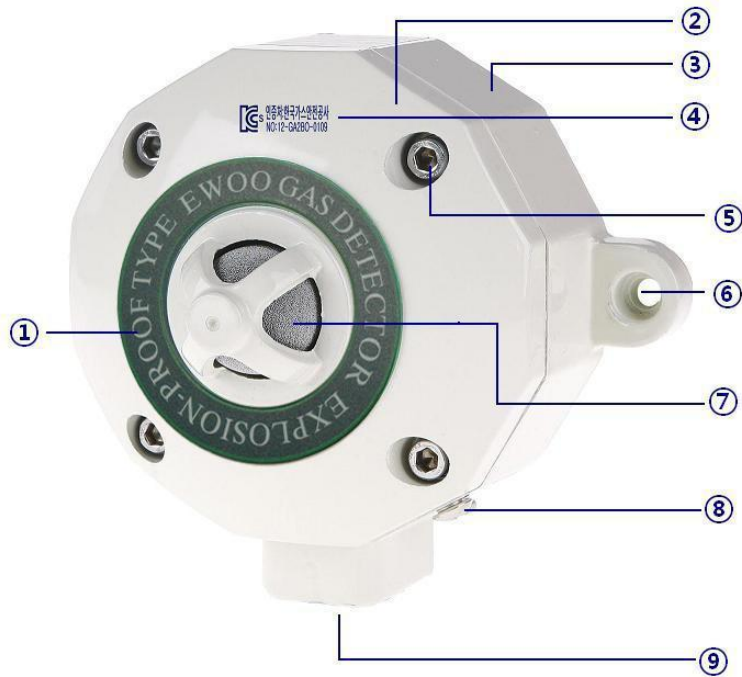

- ① Sticker (Explosion proof)
- ② Sensor cover ③ Sensor body
- ④ Explosion proof approval sticker (Korea gas safety corporation approval)
- ⑤ Cover fixing hole: The bolt for fixing cover and body of detector
(Wrench bolt M5x15)
- ⑥ Sensor fixing hole: The hole for fixing the detector by bolts or nails
- ⑦ Sensor protection filter: Sensor protection filter (bronze 300mesh)
- ⑧ Ground earth: M4x6mm
- ⑨ Cable grand; Do sealing fitting properly or access using cable glands passed the safety certification. When the way of inlet pipes and tubes of metal wires in areas that require explosion-proof

Hexagonal headed bolt and packing



Hexagonal headed bolt and packing cannot be used in the areas that require explosion-proof

3-1. INDICATOR

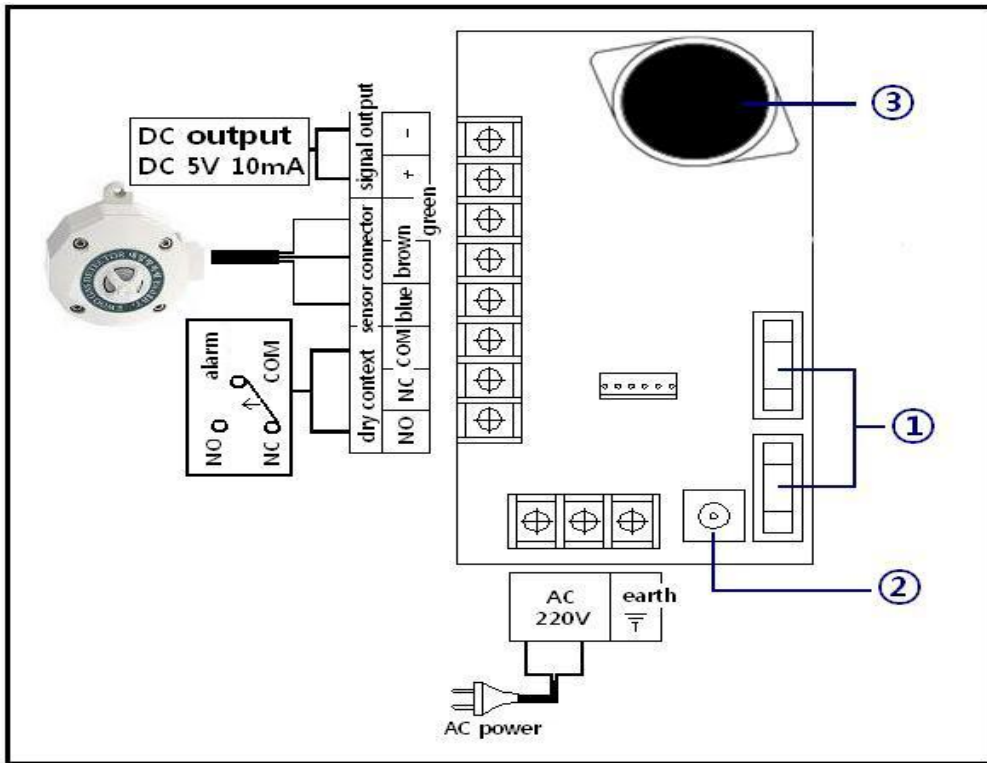

- ① AC FUSE (2EA): 220V 1A glass tube
(When it has blown, RED warning light of the fuse gets lit)
- ② Power switch: AC power supply switch
- ③ BUZZER: It makes audible alarm

WIRING DIAGRAM

- AC 220V input terminal: Please connect with rated voltage (AC 220V)
- Dry contact (NO NC COM): In normal condition, COM terminal is connected with NC terminal. And in alarm condition. COM terminal is connected with NO terminal
- Sensor connector (terminal block): Please match the wire with terminals in color

Blue (White) +	Brown (Black)-	Green (Wire of signal)
Power supply of sensor + (DC 24V)	Power supply of sensor – (DC 24V GND)	Output of Sensor (4~20mA)

- Alarm output terminal: These terminals are used when the indicator outputs the Alarm signal to the control panel and others (DC 12V 20mA)

3-2. SENSOR

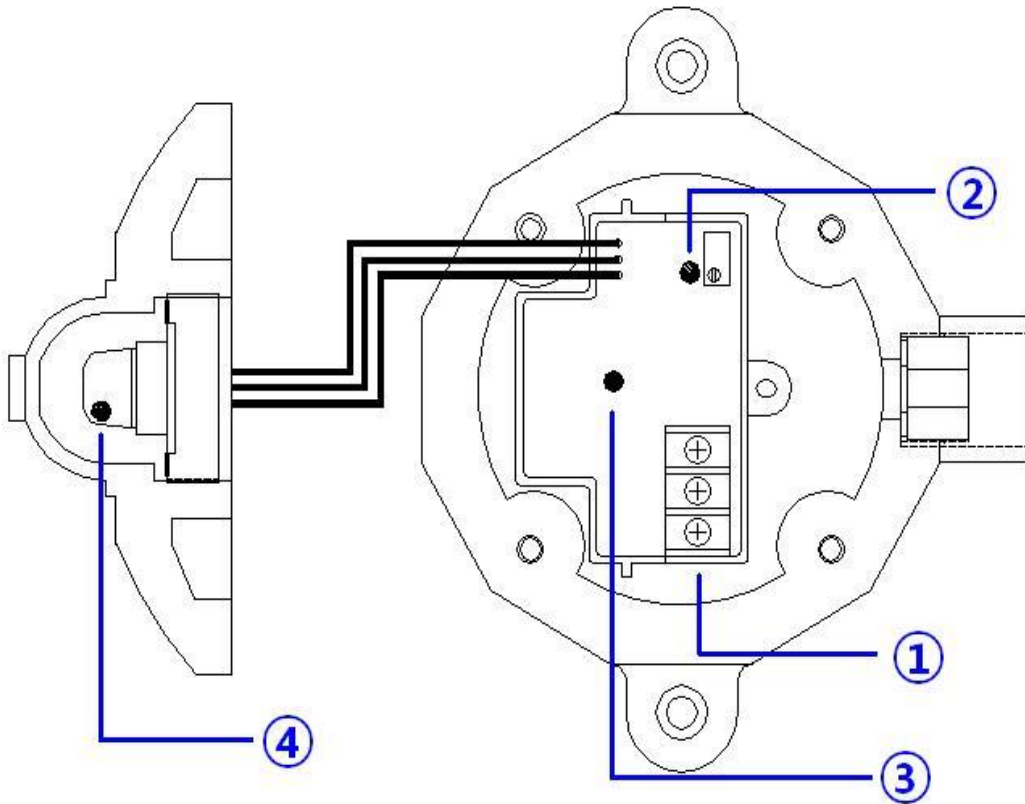

① Connector (terminal block)

Blue (White) +	Brown (Black)-	Green (Wire of signal)
Power supply of sensor + (DC 24V)	Power supply of sensor - (DC 24V GND)	Output of Sensor (4~20mA)

② Zero calibration: We release the detector with it being set. Do not attempt to modify

③ Concentration light: The brightness of yellow light changes in proportion to the Concentration of gas (eliminated in normal condition)

④ Power supply light: Green LED is lit while supplied with power

4. OPERATIONAL SYSTEM

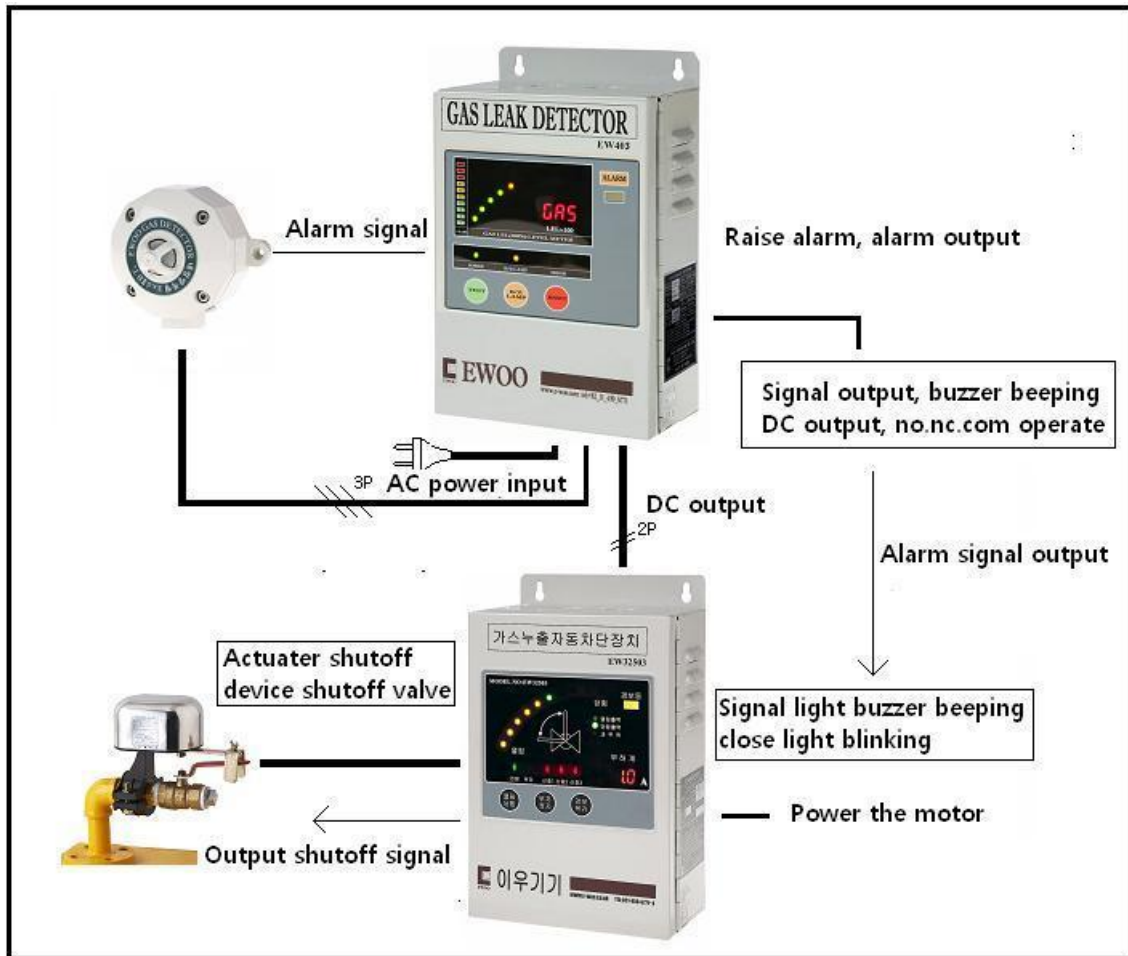

5. INSTALLATION

5-1. Where to install

- ① The detector is designed to be installed in the area that is subject to expose to gas or the area where the leaked gas tend to stay.
- ② Please determine the location of the sensor considering the kind of the Gas, cautions and condition.
- ③ If you are to detect the gas that is heavier than air, sensor be mounted at Floor or the wall within 30cm from floor, and if you are to detect the Gas that is lighter than air, sensor should be mounted at the ceiling or The wall within 30cm from ceiling

(Plus: sensor should be farther than 1m and within 4m from the gas appliance)

- ④ Please install the detector at the place that the audible alarm is able to be Heard so that manager can take follow-up measures.

5-2. Installations drawing

※ PLACE TO INSTALL: kitchen, Boiler room, Room of pressure regulator, Gas storage

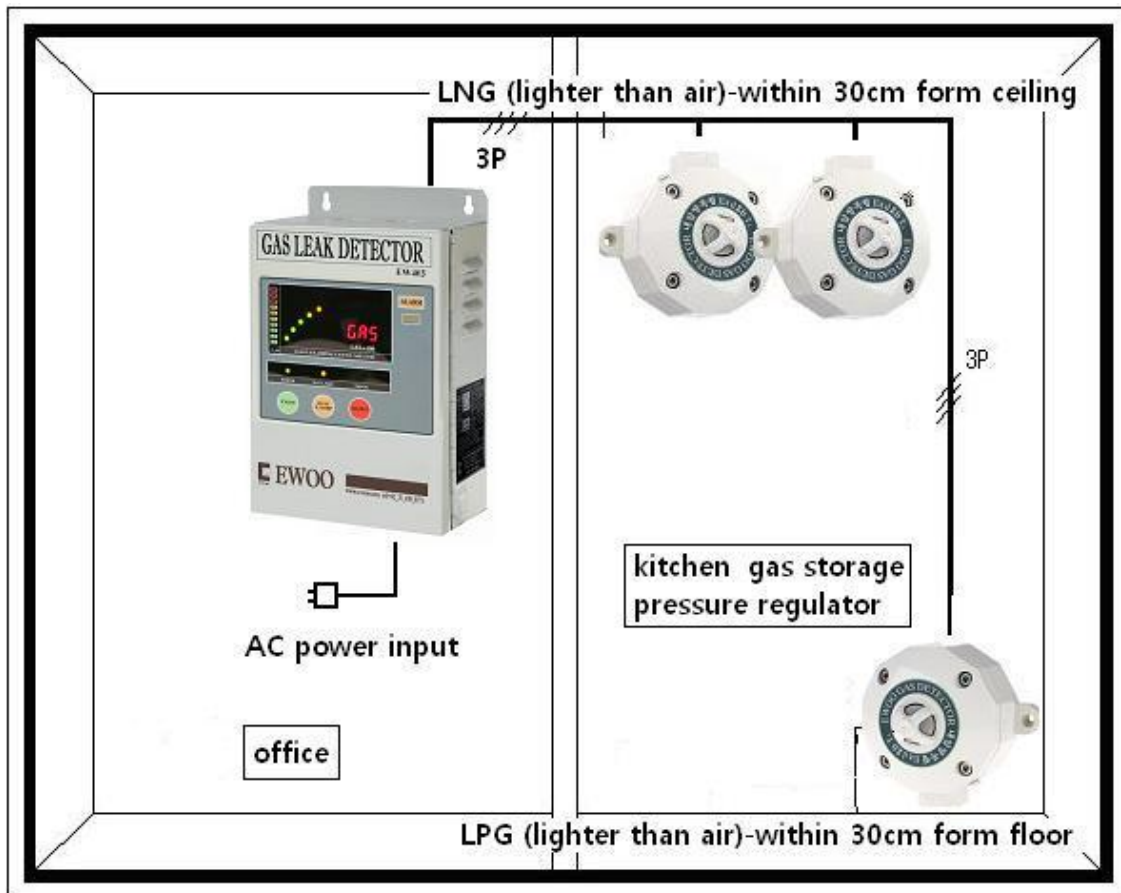

6. INSTALLATION & CAUTIONS

6-1. INSTRUCTION

- ① Please open the case and connect the sensor with the indicator. And connect the AC 220V power supply as well.
- ② Please turn on the power supply switch and wait for warm up time 1(minute) in 1minute, the detector begins to operate.
- ③ Fault light (ERROR) on the UNIT panel gets lit when the fuse for the Sensor has blown or the connection wire between the sensor and The indicator is disconnected or short-circuited. Or the sensitivity of The sensor has been lost.
- ④ If you are to test the operation of the detector, please press the test Button on UNIT panel, Then the concentration increases as if gas Is detected actually. And if the level exceeds the alarm pint, the Detector makes visual and audible alarm.

- ⑤ If you want to stop the audible alarm, please press the alarm mute Button (B/Z stop) If you do, alarm mute warning light (B/Z Stop) blinks And the audible alarm becomes mute.
- ⑥ When the fault light gets lit, please check the connection between Sensor and indicator.

6-2. CAUTIONS

1. Do not attempt to disassemble, repair, remodel or convert.
2. If you purchase the product which has earth terminal, please install an earth wire.
3. Do not touch the power cord or main body with wet hand.
4. Do not disturb the ventilation of the Sensor
5. Be careful not to damage the power cord.
6. Be cautious about using the silicon glue which could affect the Sensor. Silicon glue could cause malfunctioning.
7. Please use the rated voltage (AC 220V) written on the product.
8. Do not spray the Sensor directly with air freshener, insecticide, hair spray etc.
9. Please use standard gas when testing.
10. Please connect Indicator with same Sensor in serial number.
11. Do not use for the gas that is not target one.
12. Please check the sensing device more than once a year.
13. Areas to avoid
 1. Near drafts caused by heating, ventilating, fans and doors
 2. Near vapor, steam, exhaust gas, dust, strong wind and other gases
 3. Areas of high heat and humidity.

7. Dimensions

